



## Type sheet

Deflagration and endurance burning proof pressure and vacuum relief valve  
**KITO® VD/KS-IIB1-...**



### Application

As an end-of-line flame arrester, explosion and endurance burning proof for all inflammable liquids and vapors of explosion group IIB1 and also for alcohols with a maximum experimental safe gap (MESG) ≥ 0.85 mm and an maximum operating temperature of 60 °C. Safety valve for out breathing pipes of storage tanks as a protection against pressure resp. vacuum. By appropriate pressure adjustment the gasification losses of the storage product are prevented or strongly limited. Installation on top of storage vessels. Available with an explosion and endurance burning proofed condensate drain device.

*With additional examination and approval, applicable also for alcohols (ethanol, methanol...)*

### Dimensions (mm) and settings (mbar)

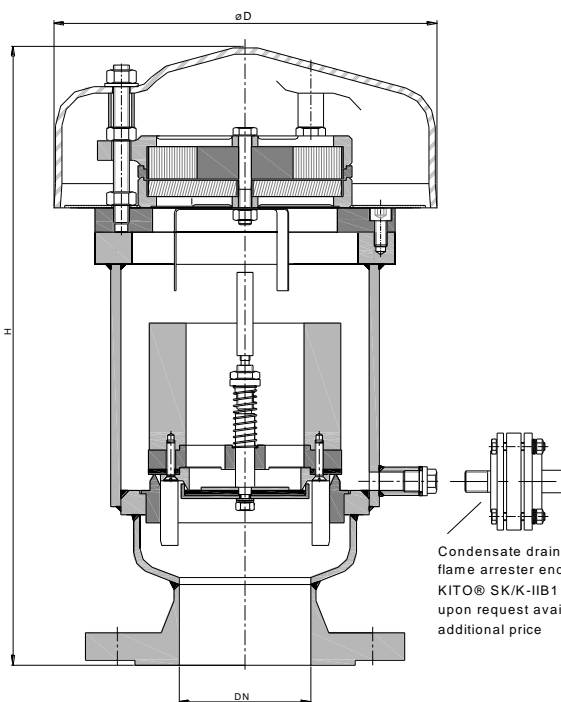

Condensate drain flame arrester – End-of-line deflagration flame arrester endurance burning proof  
KITO® SK/K-IIB1 -type sheet L31 N-  
upon request available against additional price

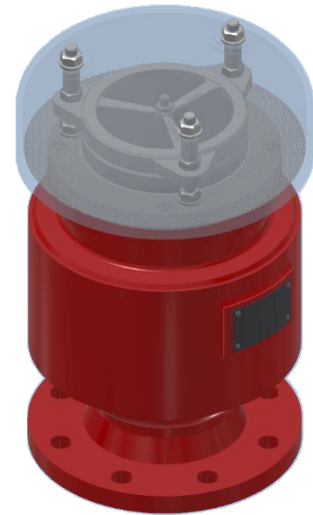

DN		D	H		~kg	vacuum min. - max.	setting pressure			
DIN	ASME		DIN	ASME			min. - max.	min. - max. (with housing extension)		
50 PN 16	2"	240	332	351		3 - 100	10 - 50	> 50 - 200		
80 PN 16	3"		383	403					3 - 50	> 63 - 200
100 PN 16	4"		381	406					3 - 50	> 60 - 200

Indicated weights are understood without weight load and refer to the standard design  
Higher settings on request !

### Example for order

**KITO® VD/KS-IIB1-50-A**  
(design with flange connection DN 50 PN 16)

**Type examination certificate to EN ISO 16852 and CE-marking in accordance to ATEX-Directive 2014/34/EU**

## Type sheet

Deflagration and endurance burning  
proof pressure and vacuum relief valve  
**KITO® VD/KS-IIB1-...**

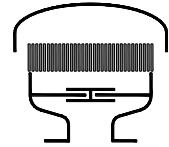

### Design

	standard	optionally
housing	steel	stainless steel mat. no. 1.4571
valve seat, valve spindle	stainless steel mat. no. 1.4571	
load weight	stainless steel mat. no. 1.4571	
valve sealing	NBR	Viton, PTFE, EPDM, metal sealing
	<i>≥ 100 mbar only PTFE or metal sealing (valve pallet for pressure)</i>	
valve pallet (vacuum)	spring loaded	
valve pallet (pressure)	weight loaded	
KITO®-flame arrester element	completely interchangeable	
KITO®-casing / KITO®-grid	stainless steel mat. no. 1.4408 / 1.4310	stainless steel mat. no. 1.4408 / 1.4571
weather hood	PMMA	
protective screen	PA6	
flange connection	EN 1092-1 type B1	ASME B16.5 Class 150 RF

### Performance curves

Flow capacity  $V$  based on air of a density  $\rho = 1.29 \text{ kg/m}^3$  at  $T = 273 \text{ K}$  and atmospheric pressure  $p = 1.013 \text{ mbar}$ . For other gases the flow can be approximately calculated by

$$\dot{V}_{40\%} = \dot{V}_b \cdot \sqrt{\frac{\rho_b}{1.29}} \quad \text{or} \quad \dot{V}_b = \dot{V}_{40\%} \cdot \sqrt{\frac{1.29}{\rho_b}}$$

The indicated flow rates will be reached by an accumulation of 40% above valve's setting (see DIN 4119).  
If the allowable overpressure is less 40%, please consult der factory for the corrected volume flow.

